



Coffee roasting equipment



RM2

-
- The Lab Roasters RM2 are the start-up machines for artisan roasting. In fact, they can offer, together with the small dimensions, all the technological components of the larger machines. Then they allow the roaster to make a high-quality gourmet coffee.
 - The machine is complete with a modulating burner, air aspirator and rotation speed thanks to the modular drum that allows a complete and constant control during the roasting phase, to test and express all the organoleptic characteristics of coffee.
 - The Lab Roasters RM2 are produced in two versions, gas or electric.



Coffee roasting equipment

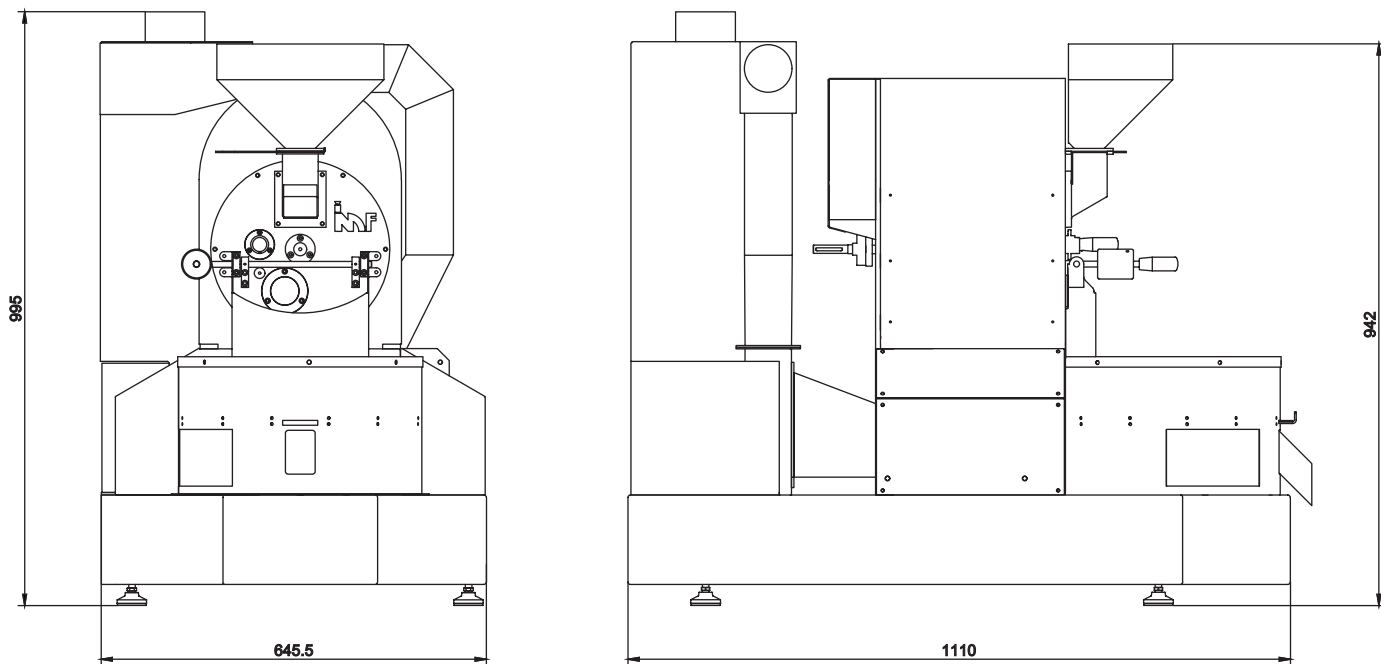

SHOP ROASTERS RM2

MODEL	Kg/CYCLE	OUTPUT (Kg/h)	T. CYCLE (min)	POWER (KW)	FUEL	ØPIPPING (mm)
RM 2	2,5	10	12/18	14	gpl/metano	100

The given data are to be considered approximative

ROASTING TECHNOLOGY

Indirect
flame

Forced
hot air

Perforated
drum

Fan
Speed

Ground
Speed

USB Port
Connection